

## Product Data Sheet

Product Name: **COVER n°1 – Translucent**

Material: **Rigid PVC, unplasticized** **thickness: 12/10**

Profil :

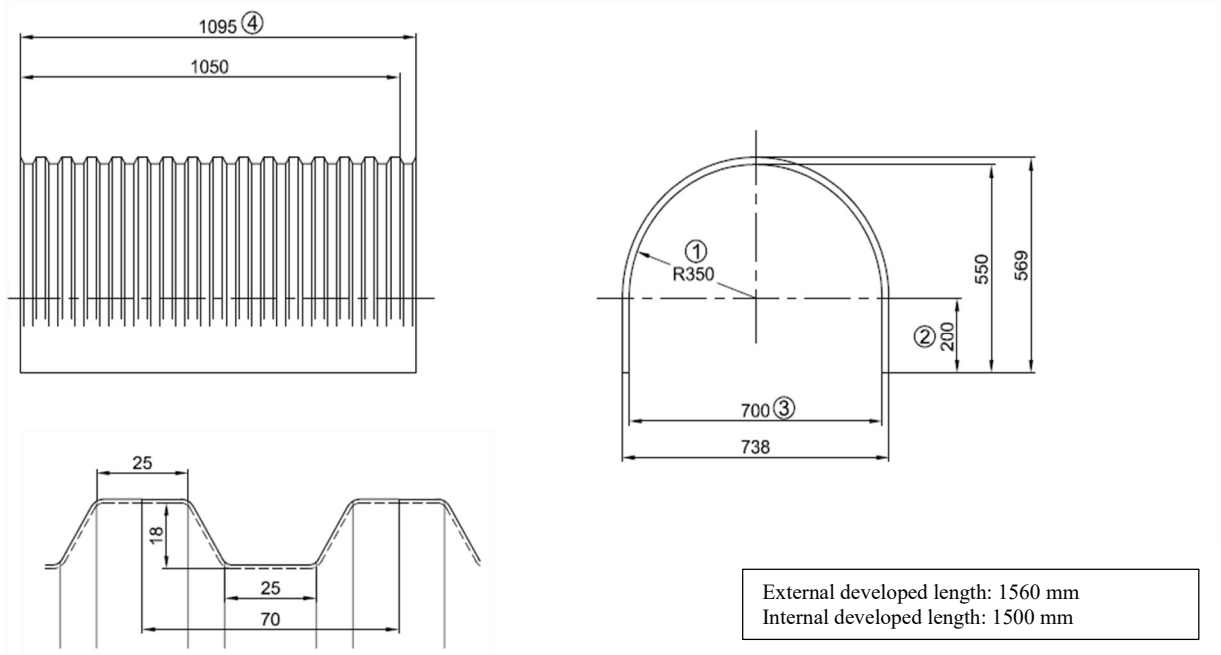

Field of application: **Removable cover for belt conveyors with a width of 400 mm**

Unit weight	:	3.6 kg
Light transmission	:	44 %
Operating temperature	:	-20 à 55 °C
Expansion coefficient	:	0.08 mm / m .C°
Fire resistance	:	B s1 d0
Anti-UV treatment	:	on both sides
Mechanical strength	:	> 300 KJ/m <sup>2</sup>

Rigid, unplasticized PVC; bisphenol A-free and no phthalates; resistant to corrosion, salt environments and chemical fumes. (see doc 26-009 )

Compatibility with foodstuffs and ingredients in terms of chemical resistance without corrosion or degradation (oils; grease; preservatives; acidity; liquid) **allowing use in food splash areas** in accordance with generally required criteria.

- Chemical resistance to cleaning and disinfection and cold sterilization
- Non-absorbance of the material / no re-lightening / no exudation
- Easy accessibility of the different surfaces; easy to dismantle and clean.
- Overall ergonomics allowing the non-accumulation of material and possibly the evacuation towards the outside of drips and condensates.
- Smooth surface finish without roughness to prevent sticking and material accumulation  
(Ra:050 µm - Rz:3.0 µm)

100% recyclable product.



The fixing of these covers is done with the help of 2 stainless steel straps available on request.

## Product Data Sheet

Product Name: **COVER n°2 – Translucent**

Material: **Rigid PVC, unplasticized** **thickness: 12/10**

Profil :

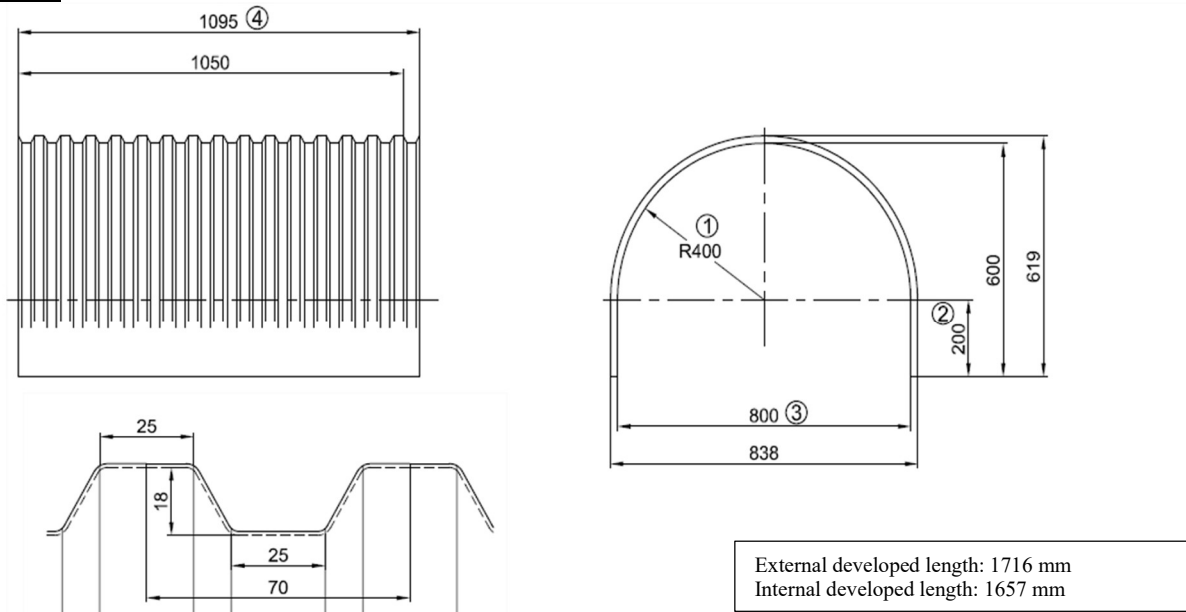

Field of application: **Removable cover for belt conveyors with a width of 500 mm**

Unit weight	:	4.0 kg
Light transmission	:	44 %
Operating temperature	:	-20 à 55 °C
Expansion coefficient	:	0.08 mm / m .C°
Fire resistance	:	B s1 d0
Anti-UV treatment	:	on both sides
Mechanical strength	:	> 300 KJ/m <sup>2</sup>

Rigid, unplasticized PVC; bisphenol A-free and no phthalates; resistant to corrosion, salt environments and chemical fumes. (see doc 26-009)

Compatibility with foodstuffs and ingredients in terms of chemical resistance without corrosion or degradation (oils; grease; preservatives; acidity; liquid) **allowing use in food splash areas** in accordance with generally required criteria.

- Chemical resistance to cleaning and disinfection and cold sterilization
- Non-absorbance of the material / no re-lightening / no exudation
- Easy accessibility of the different surfaces; easy to dismantle and clean.
- Overall ergonomics allowing the non-accumulation of material and possibly the evacuation towards the outside of drips and condensates.
- Smooth surface finish without roughness to prevent sticking and material accumulation (Ra:050 µm - Rz:3.0 µm)

100% recyclable product.



The fixing of these covers is done with the help of 2 stainless steel straps available on request.

## Product Data Sheet

Product Name: **COVER n°3 – Translucent**

Material: **Rigid PVC, unplasticized** **thickness: 12/10**

Profil :

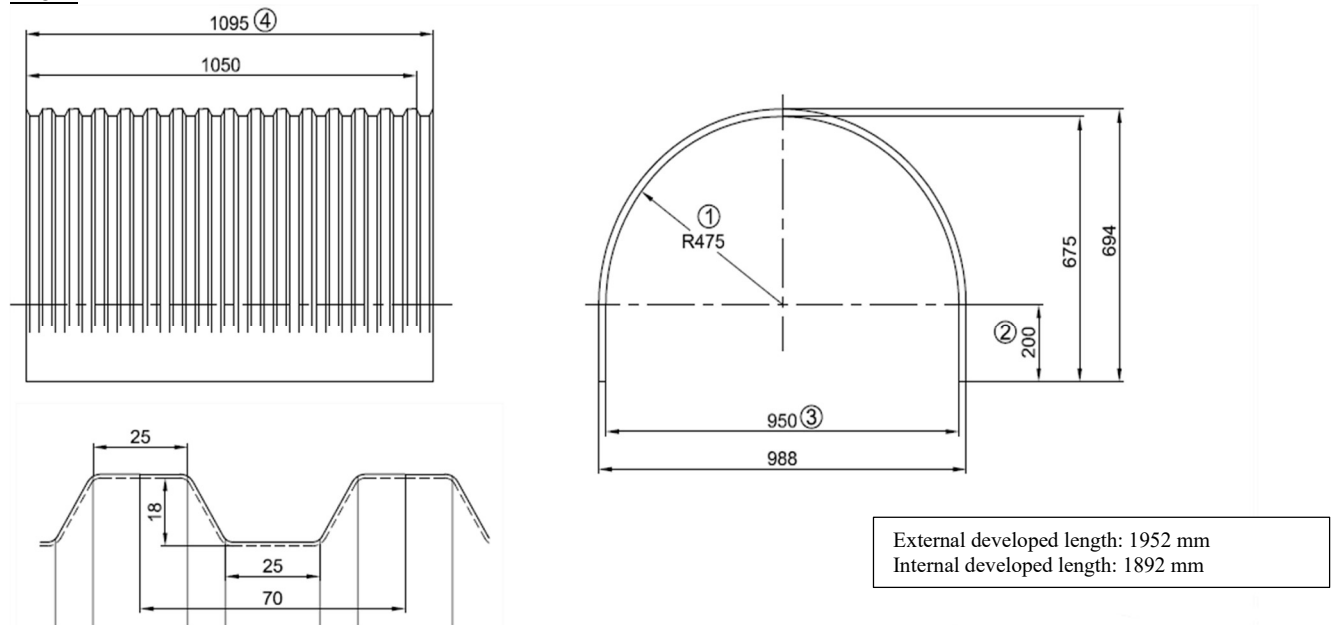

Field of application: **Removable cover for belt conveyors with a width of: 650 mm**

Unit weight	:	4.5 kg
Light transmission	:	44 %
Operating temperature	:	-20 à 55 °C
Expansion coefficient	:	0.08 mm / m .C°
Fire resistance	:	B s1 d0
Anti-UV treatment	:	on both sides
Mechanical strength	:	> 300 KJ/m <sup>2</sup>

Rigid, unplasticized PVC; bisphenol A-free and no phthalates; resistant to corrosion, salt environments and chemical fumes. (see doc 26-009)

Compatibility with foodstuffs and ingredients in terms of chemical resistance without corrosion or degradation (oils; grease; preservatives; acidity; liquid) **allowing use in food splash areas** in accordance with generally required criteria.

- Chemical resistance to cleaning and disinfection and cold sterilization
- Non-absorbance of the material / no re-lightening / no exudation
- Easy accessibility of the different surfaces; easy to dismantle and clean.
- Overall ergonomics allowing the non-accumulation of material and possibly the evacuation towards the outside of drips and condensates.
- Smooth surface finish without roughness to prevent sticking and material accumulation  
(Ra:050 µm - Rz :3.0 µm)

100% recyclable product.



The fixing of these covers is done with the help of 2 stainless steel straps available on request.

## Product Data Sheet

Product Name: **COVER n°4 – Translucent**

Material: **Rigid PVC, unplasticized** **thickness: 12/10**

Profil :

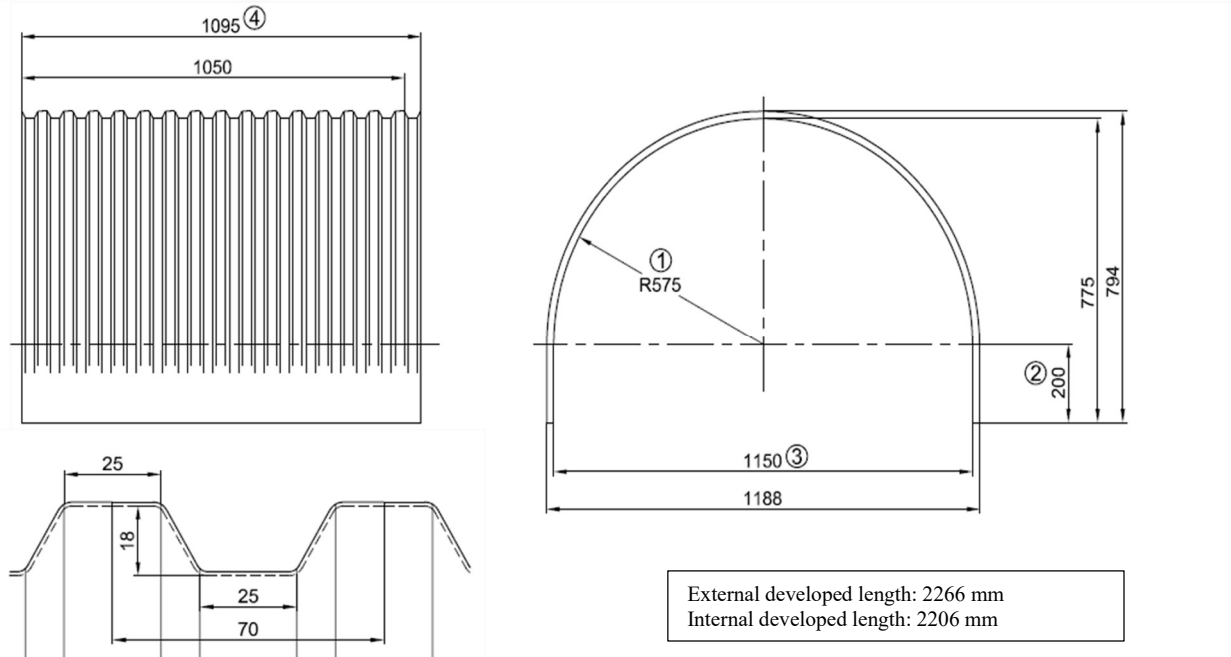

Field of application: **Removable cover for belt conveyors with a width of: 800 mm**

Unit weight	:	5.3 kg
Light transmission	:	44 %
Operating température	:	-20 à 55 °C
Expansion coefficient	:	0.08 mm / m .C°
Fire resistance	:	B s1 d0
Anti-UV treatment	:	on both sides
Mechanical strength	:	> 300 KJ/m <sup>2</sup>

Rigid, unplasticized PVC; bisphenol A-free and no phthalates; resistant to corrosion, salt environments and chemical fumes. (see doc 26-009)

Compatibility with foodstuffs and ingredients in terms of chemical resistance without corrosion or degradation (oils; grease; preservatives; acidity; liquid) **allowing use in food splash areas** in accordance with generally required criteria.

- Chemical resistance to cleaning and disinfection and cold sterilization
- Non-absorbance of the material / no re-lightening / no exudation
- Easy accessibility of the different surfaces; easy to dismantle and clean.
- Overall ergonomics allowing the non-accumulation of material and possibly the evacuation towards the outside of drips and condensates.
- Smooth surface finish without roughness to prevent sticking and material accumulation (Ra:050 µm - Rz:3.0 µm)

100% recyclable product.



The fixing of these covers is done with the help of 3 stainless steel straps available on request.

## Product Data Sheet

Product Name: **COVER n°5 – Translucent**

Material: **Rigid PVC, unplasticized** **thickness: 12/10**

Profil :

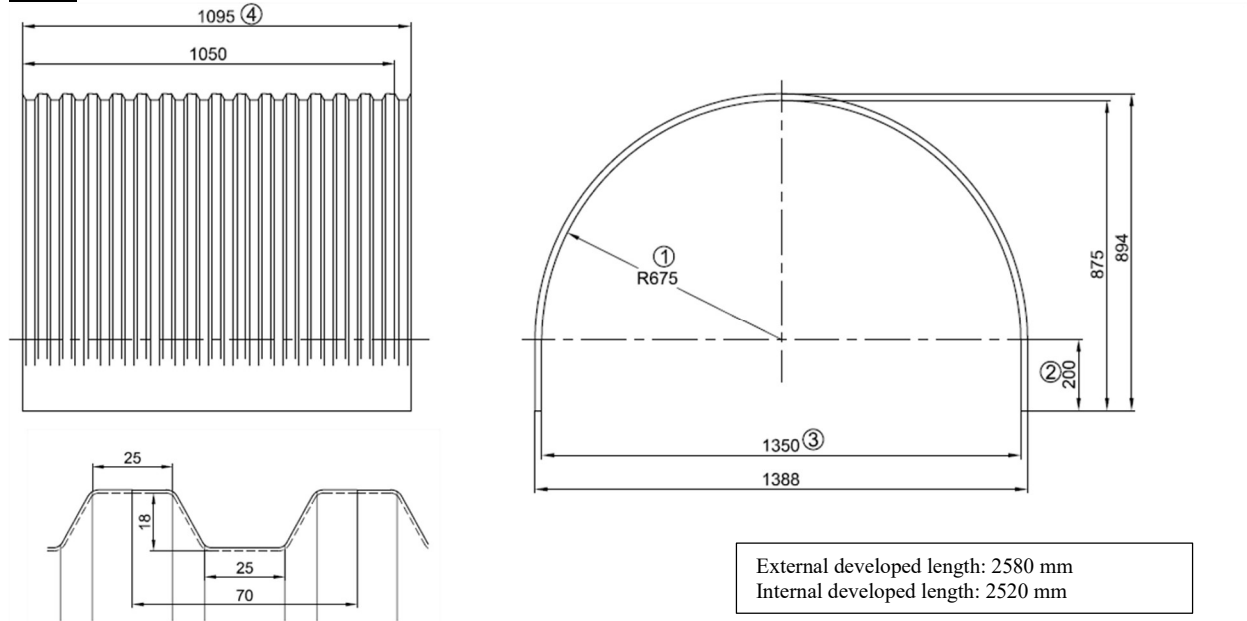

Field of application: **Removable cover for belt conveyors with a width of: 1000 mm**

Unit weight	:	6.0 kg
Light transmission	:	44 %
Operating température	:	-20 à 55 °C
Expansion coefficient	:	0.08 mm / m .C°
Fire resistance	:	B s1 d0
Anti-UV treatment	:	on both sides
Mechanical strength	:	> 300 KJ/m <sup>2</sup>

Rigid, unplasticized PVC; bisphenol A-free and no phthalates; resistant to corrosion, salt environments and chemical fumes. (see doc 26-009)

Compatibility with foodstuffs and ingredients in terms of chemical resistance without corrosion or degradation (oils; grease; preservatives; acidity; liquid) **allowing use in food splash areas** in accordance with generally required criteria.

- Chemical resistance to cleaning and disinfection and cold sterilization
- Non-absorbance of the material / no re-lightening / no exudation
- Easy accessibility of the different surfaces; easy to dismantle and clean.
- Overall ergonomics allowing the non-accumulation of material and possibly the evacuation towards the outside of drips and condensates.
- Smooth surface finish without roughness to prevent sticking and material accumulation  
(Ra:050 µm - Rz:3.0 µm)

100% recyclable product.



The fixing of these covers is done with the help of aluminum arch and fixing kit available on request.

## Product Data Sheet

Product Name: **COVER n°6 – Translucent**

Material: **Rigid PVC, unplasticized** **thickness: 12/10**

Profil :

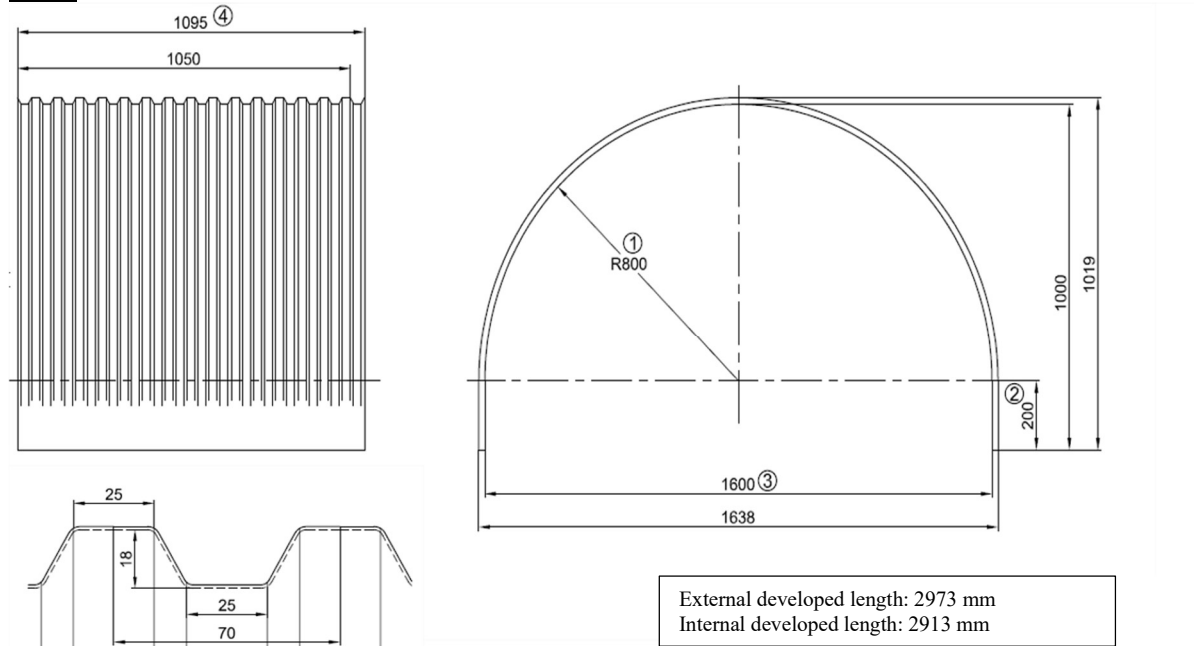

Field of application: **Removable cover for belt conveyors with a width of: 1200 mm**

Unit weight	:	6.9 kg
Light transmission	:	44 %
Operating temperature	:	-20 à 55 °C
Expansion coefficient	:	0.08 mm / m .C°
Fire resistance	:	B s1 d0
Anti-UV treatment	:	on both sides
Mechanical strength	:	> 300 KJ/m <sup>2</sup>

Rigid, unplasticized PVC; bisphenol A-free and no phthalates; resistant to corrosion, salt environments and chemical fumes. (see doc 26 -009)

Compatibility with foodstuffs and ingredients in terms of chemical resistance without corrosion or degradation (oils; grease; preservatives; acidity; liquid) **allowing use in food splash areas** in accordance with generally required criteria.

- Chemical resistance to cleaning and disinfection and cold sterilization
- Non-absorbance of the material / no re-lightening / no exudation
- Easy accessibility of the different surfaces; easy to dismantle and clean.
- Overall ergonomics allowing the non-accumulation of material and possibly the evacuation towards the outside of drips and condensates.
- Smooth surface finish without roughness to prevent sticking and material accumulation (Ra:050 µm - Rz:3.0 µm)

100% recyclable product.



The fixing of these covers is done with the help of aluminum arch and fixing kit available on request.

## Product Data Sheet

Product Name: **COVER n°7 – Translucent**

Material: **Rigid PVC, unplasticized** **thickness: 12/10**

Profil :

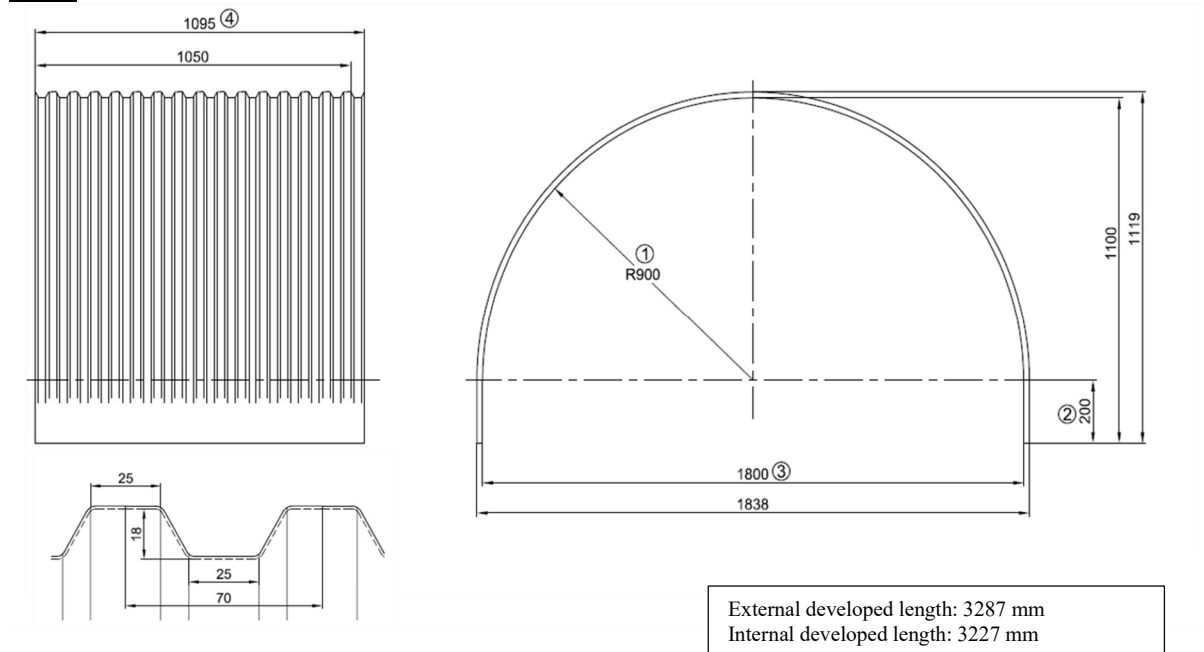

Field of application: **Removable cover for belt conveyors with a width of: 1400 mm**

Unit weight	:	7.7 kg
Light transmission	:	44 %
Operating temperature	:	-20 à 55 °C
Expansion coefficient	:	0.08 mm / m .C°
Fire resistance	:	B s1 d0
Anti-UV treatment	:	on both sides
Mechanical strength	:	> 300 KJ/m <sup>2</sup>

Rigid, unplasticized PVC; bisphenol A-free and no phthalates; resistant to corrosion, salt environments and chemical fumes. (see doc 26-009)

Compatibility with foodstuffs and ingredients in terms of chemical resistance without corrosion or degradation (oils; grease; preservatives; acidity; liquid) **allowing use in food splash areas** in accordance with generally required criteria.

- Chemical resistance to cleaning and disinfection and cold sterilization
- Non-absorbance of the material / no re-lightening / no exudation
- Easy accessibility of the different surfaces; easy to dismantle and clean.
- Overall ergonomics allowing the non-accumulation of material and possibly the evacuation towards the outside of drips and condensates.
- Smooth surface finish without roughness to prevent sticking and material accumulation (Ra:050 µm - Rz:3.0 µm)

100% recyclable product.



The fixing of these covers is done with the help of aluminum arch and fixing kit available on request.

## Product Data Sheet

Product Name: **COVER n°8 – Translucent**

Material: **Rigid PVC, unplasticized** **thickness: 12/10**

Profil :

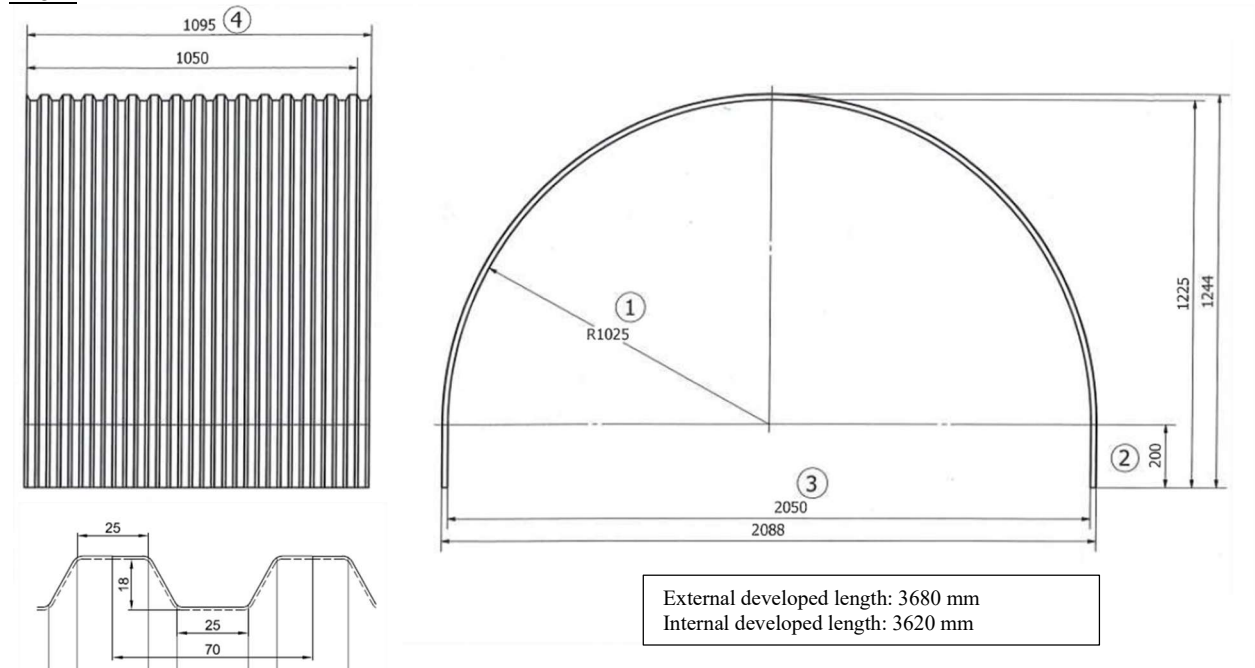

Field of application: **Removable cover for belt conveyors with a width of 1600 mm**

Unit weight	:	8.6 kg
Light transmission	:	44 %
Operating temperature	:	-20 à 55 °C
Expansion coefficient	:	0.08 mm / m .C°
Fire resistance	:	B s1 d0
Anti-UV treatment	:	on both sides
Mechanical strength	:	> 300 KJ/m <sup>2</sup>

Rigid, unplasticized PVC; bisphenol A-free and no phthalates; resistant to corrosion, salt environments and chemical fumes. (see doc 26-009)

Compatibility with foodstuffs and ingredients in terms of chemical resistance without corrosion or degradation (oils; grease; preservatives; acidity; liquid) **allowing use in food splash areas** in accordance with generally required criteria.

- Chemical resistance to cleaning and disinfection and cold sterilization
- Non-absorbance of the material / no re-lightening / no exudation
- Easy accessibility of the different surfaces; easy to dismantle and clean.
- Overall ergonomics allowing the non-accumulation of material and possibly the evacuation towards the outside of drips and condensates.
- Smooth surface finish without roughness to prevent sticking and material accumulation (Ra:050 µm - Rz:3.0 µm)

100% recyclable product.



The fixing of these covers is done with the help of aluminum arch and fixing kit available on request.